

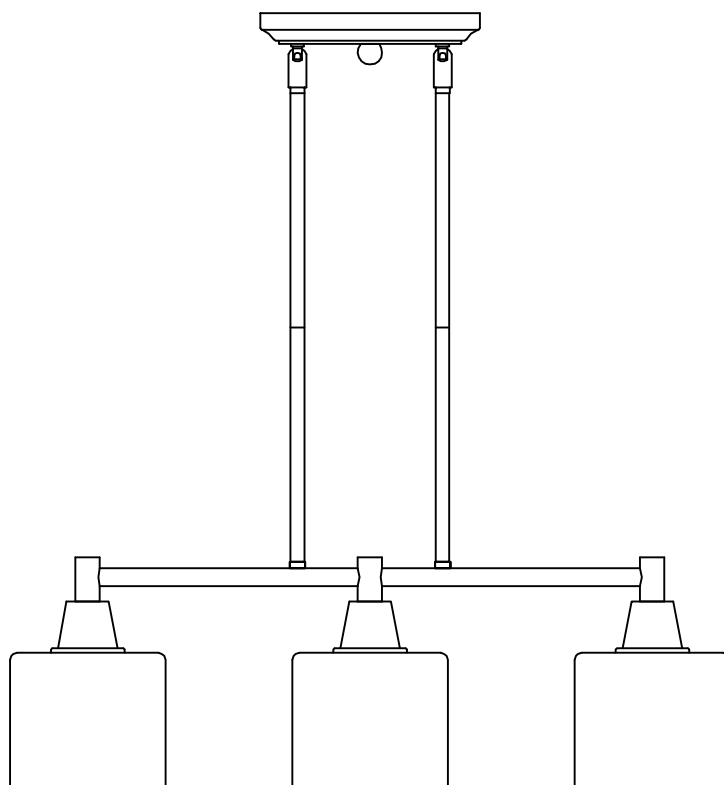

Item # XXXXX
Model # HDP12070

USE AND CARE GUIDE

ARGYLE 3-LIGHT ISLAND



Questions, problems, missing parts? Before returning to the store,
call Hampton Bay Customer Service
8 a.m.-6 p.m., EST, Monday-Friday

1-877-527-0313

HOMEDEPOT.COM

THANK YOU

We appreciate the trust and confidence you have placed in Hampton Bay through the purchase of this light fixture. We strive to continually create quality products designed to enhance your home. Visit us online to see our full line of products available for your home improvement needs.

Thank you for choosing Hampton Bay!

Table of Contents

Safety Information	2	Assembly	5
Warranty	2	Installation	6
Pre-Installation	3	Care and Cleaning	7
Planning installation	3	Troubleshooting	7
Tools Required	3		
Materials Required	3		
Hardware Included	3		
Package Contents	4		

Safety Information

- Consult a qualified electrician with any electrical questions you may have.



IMPORTANT: Inspect the wire insulation for any cuts, abrasions, or exposed copper that may have occurred during shipping. If there is a defect in the wire, do not continue the assembly process. Please call our Customer Service Team at 1-877-527-0313.

Warranty

The manufacturer warrants this lighting fixture to be free from defects in the materials and workmanship for a period of one (1) year from date of purchase. This warranty applies only to the original consumer purchaser and only to products used in normal use. If this product is found to be defective, the manufacturer's only obligation, and your exclusive remedy, is the repair or replacement of the product at the manufacturer's discretion, provided that the product has not been damaged through misuse, abuse, accident, modifications, alterations, neglect or mishandling. This warranty shall not apply to any product that is found to have been improperly installed, assembled, or used in any way not in accordance with the instructions supplied with the product. This warranty shall not apply to a failure of the product as a result of an accident, misuse, abuse, negligence, alteration, faulty installation, or any other failure not relating to faulty material or workmanship. This warranty shall not apply to the finish on any portion of the product due to weathering, as this is considered normal wear. The manufacturer does not warrant and specifically disclaims any warranty, whether expressed or implied, other than the warranty contained herein. The manufacturer specifically disclaims any liability and shall not be liable for any consequential or incidental loss or damage, including but not limited to, any labor or expense costs involved in the replacement or repair of the product.

Contact the Customer Service Team at 1-877-527-0313 or visit www.HomeDepot.com.



Pre-Installation

PLANNING INSTALLATION

Read all instructions before assembly.

To avoid damaging this product, assemble it on a soft, non-abrasive surface such as carpet or cardboard. Inspect each part for defects that may have occurred during shipping.

Keep your receipt and these instructions for proof of purchase.

TOOLS REQUIRED



Safety goggles

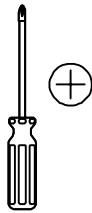

Phillips screwdriver

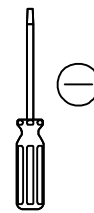

Flathead screwdriver



Wire strippers



Wire cutters

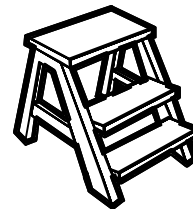

Ladder

MATERIALS REQUIRED



60-watt max. type A bulb (3)



Electrical tape

HARDWARE INCLUDED



NOTE: Hardware not shown to actual size.



—AA



—BB



—CC



—DD



—EE



—FF

Part	Description	Quantity
AA	Wire nut	3
BB	Cross bar	1
CC	Outlet box screw	2
DD	Lock nut	1
EE	Ground screw	1
FF	Nipple	1

Pre-Installation (continued)

PACKAGE CONTENTS

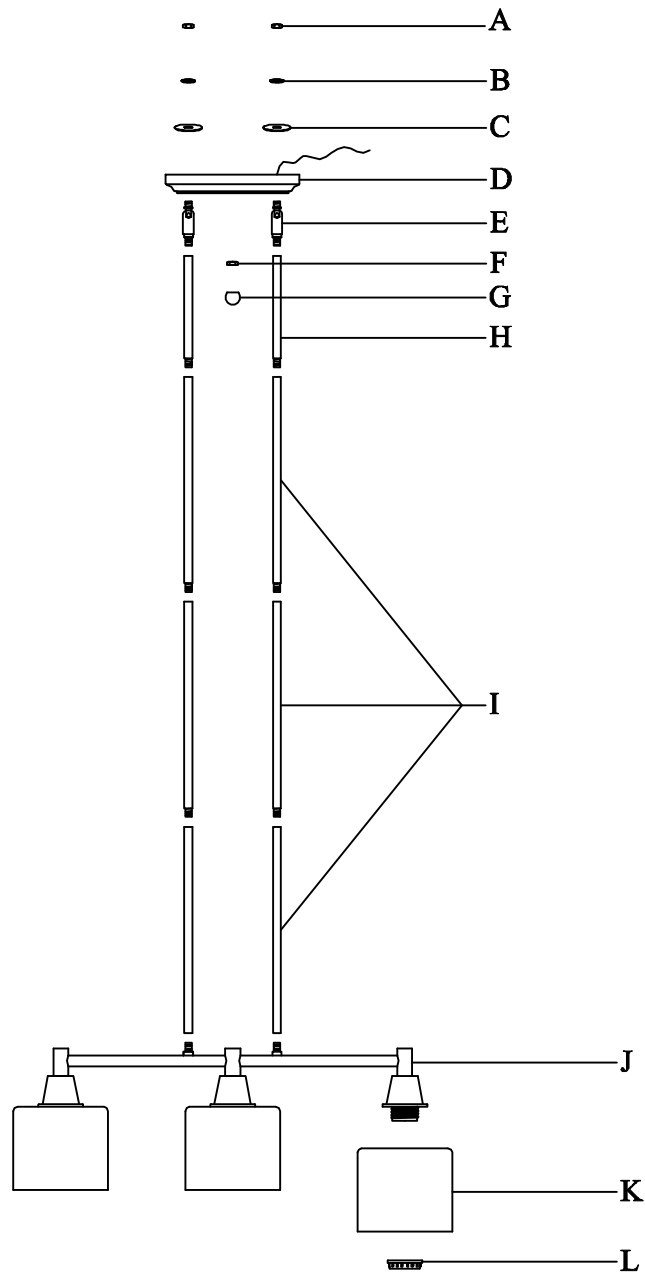

Part	Description	Quantity	Part	Description	Quantity
A	Nut	2	G	Finial	1
B	Tooth lock washer	2	H	6" tube	2
C	Metal washer	2	I	12" tube	6
D	Canopy	1	J	Fixture body	1
E	Swivel	2	K	Glass shade	3
F	Nut	1	L	Socket ring	3



Assembly

1 Assembling the tubes and body to the canopy

- Carefully unpack the fixture, lay out all parts on clean surface.
- Determine how many extension tubes you would like to use. The numbers of tubes you use depends on the length you desire for the installed light fixture.
- Feed the fixture wires up through the 12" tubes (I), the 6" tubes (H) and then the swivels (E).
- Attach the desired number of tubes (H and I) to the fixture body (J) by screwing the tubes in a clockwise direction.
- Screw the two swivels (E) to end of the tubes.
- Insert the two swivels (E) into the holes in the canopy (D), then secure with two metal washers (C), two tooth lock washers (B) and two nuts (A).

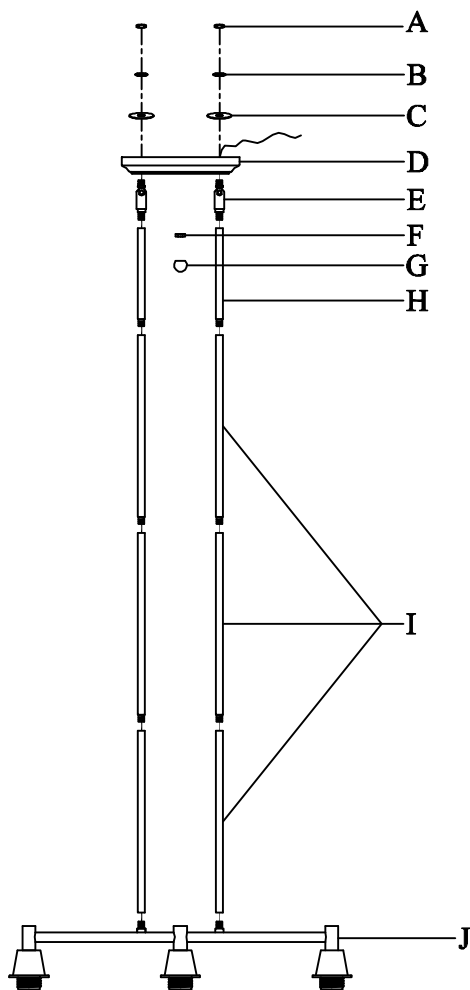

2 Attaching the glass shades

- Place a glass shade (K) over each socket and secure with a socket ring (L).
- Install a 60-watt max. type A bulb (not included) into each socket on the light fixture.

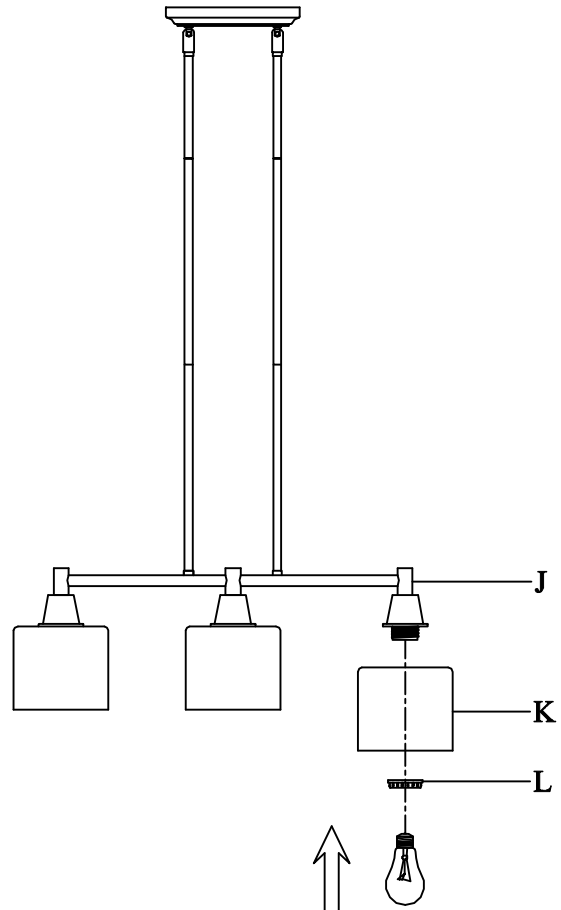

Installation

1 Installing the cross bar

- Turn off the switch at the wall.
- Turn the power off at the main fuse box.
- Screw the nipple (FF) into the hole in the cross bar (BB) and secure with a lock nut (DD).
- Attach the cross bar (BB) to the ceiling outlet box using the outlet box screws (CC).

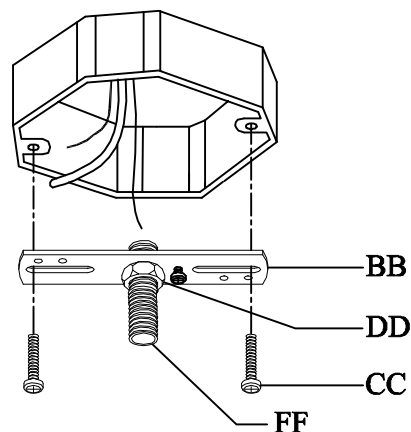

2 Connecting the wires

- Install the fixture bare silver ground wire (GG) under the ground screw (EE) on the cross bar (BB).
- Connect the fixture and supply ground wires (GG) in the outlet box using a wire nut (AA).
- Connect the white fixture and white (or ribbed) supply wires (HH) in the outlet box using a wire nut (AA).
- Connect the black fixture and black (or red) supply wires (II) in the outlet box using a wire nut (AA).

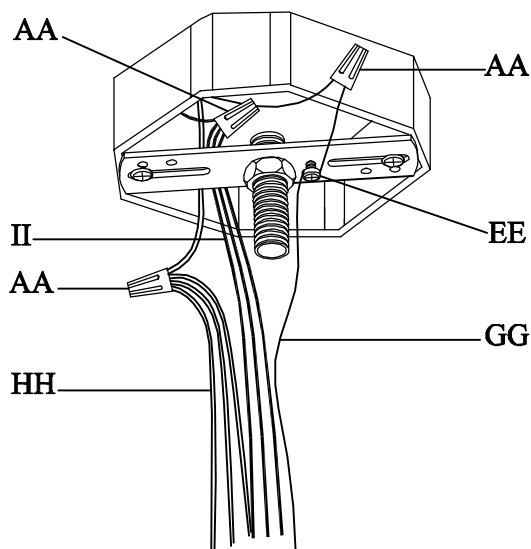

3 Installing the fixture

- Push all excess wires into the outlet box.
- Raise the canopy (D) to the ceiling and then secure in place with the nut (F) and the finial (G).

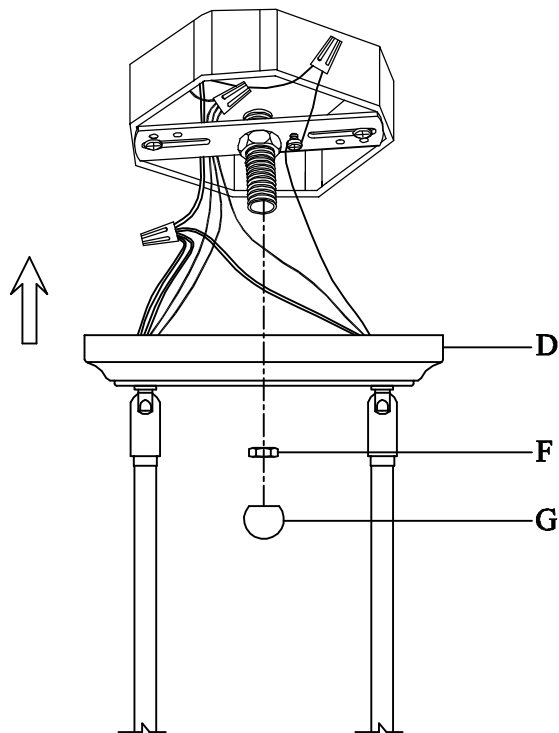

Care and Cleaning

- Clean the light fixture with a soft, dry cloth. Do not use any cleaners with chemicals, solvents, or harsh abrasives.

Troubleshooting

Problem	Possible Cause	Solution
The bulb will not light.	<input type="checkbox"/> The bulb is burned out.	<input type="checkbox"/> Replace the light bulb.
	<input type="checkbox"/> The power is off.	<input type="checkbox"/> Ensure that the power supply is turned on.
	<input type="checkbox"/> There is a faulty wire connection.	<input type="checkbox"/> Check the wiring.
	<input type="checkbox"/> The circuit breaker is off.	<input type="checkbox"/> Ensure that the circuit breaker is set in the on position.
The fuse blows or a circuit breaker trips when the light is turned on.	<input type="checkbox"/> There is an exposed wire. <input type="checkbox"/> There are too many items on one circuit.	<input type="checkbox"/> Discontinue use of the light fixture. <input type="checkbox"/> Contact a qualified electrician or call the Customer Service Team at 1-877-527-0313. <input type="checkbox"/> Unplug other items on the circuit.



Questions, problems, missing parts? Before returning to the store,
call Hampton Bay Customer Service
8 a.m.-6 p.m., EST, Monday-Friday

1-877-527-0313

HOMEDEPOT.COM

Retain this manual for future use.